

1. Basic Information about your Heat Alarm

A Heat Alarm is an early warning device. A system based on interconnected Heat Alarms and Smoke Alarms, can give you and your family valuable extra time to escape.

Note:-

- Install correctly, in the centre of the ceiling if possible.
- Test weekly with Test Button.
- Replace alkaline battery yearly or when it beeps once a minute.
- When the power is first connected the Alarm may sound for 2-3 seconds - **this is normal**.
- A Heat Alarm does not prevent fires.
- Plan your escape route.
- Proper fire protection requires Smoke Alarms in addition to Heat Alarms with all units interconnected.
- If you have any doubt or query about Heat Alarms consult the supplier or your local Fire Brigade.

2. Locating your Heat Alarm

The Heat Alarm gives a fire warning when the temperature at the unit reaches 58° C. It is ideal for kitchens, garages, boiler houses and other areas where there are normally high levels of fumes, smoke or dust i.e. places where Smoke Alarms cannot be installed without the risk of excessive nuisance alarms. A Heat Alarm should only be used in a room adjoining an escape route, in conjunction with Smoke Alarms on the escape routes.

All the Heat Alarms and Smoke Alarms should be interconnected to ensure the early warning will be heard, particularly by somebody sleeping. A Heat Alarm installed in a closed room will give early warning of fire in that room. A properly designed early warning fire system ensures the alarm is given before the escape routes become blocked with smoke - therefore there must be Smoke Alarms along the escape routes as Heat Alarms would not give sufficient warning. However, a fire in a closed room (e.g. kitchen) adjoining the escape route, can eventually cause the corridor to become smoke-logged due to smoke leaking out from around the door before adequate warning can be given by detectors in the corridor. (Smoke leaking out from a room is often cool and slow moving so it can take a long time to rise to the ceiling, and travel to a detector which could be some distance away).

Figure 1 illustrates where Heat Alarms and Smoke Alarms should be located in a typical two storey house. The following gives the recommended spacings to be used to ensure the early detection of fire and that the warning will be heard:

2

Figure 1

Recommended Locations for Interconnected Heat Alarms and Smoke Alarms

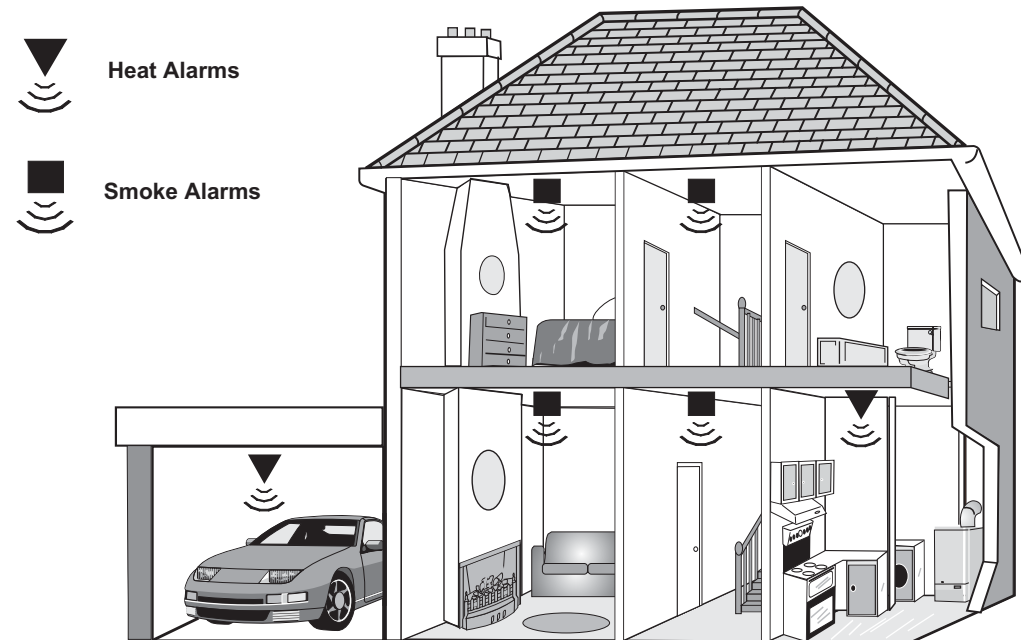

Heat Alarms

Rooms adjoining or on escape routes - kitchens, garages, boiler houses etc. where Smoke Alarms are unsuitable. Install within 5.3m (17 feet) of potential sources of fire.

Smoke Alarms

1. Within 7m (23 feet) of doors to rooms where a fire is likely to start. Corridors over 15m (46ft) should have more than one Smoke Alarm.
2. On each storey.
3. Within 3m (10 feet) of bedroom doors - so warning will be heard.
4. All other rooms where a fire could start (except those with cooking/car fumes or condensation).

3. Positioning your Heat Alarm

Location must comply with applicable building regulations.

(a) Ceiling Mounting

Hot smoke rises and spreads out, so the Heat Alarm must be put on the ceiling - preferably in the centre. The sensitive element (in the cylindrical protrusion) must not be less than 25mm (1 inch) or more than 150mm (6 inches) below the ceiling or roof.

3

The air is "dead" and does not move in corners, therefore Heat Alarms must be mounted away from corners. Place the unit at least 30cm (12 inches) from any light fitting or decorative object which might obstruct the heat travelling to the Alarm. Keep at least 15 cm (6 inches) away from walls and corners. (See figure 2). Wall mounting is not recommended for Heat Alarms. If the ceiling has a pitched roof install an Alarm within each apex.

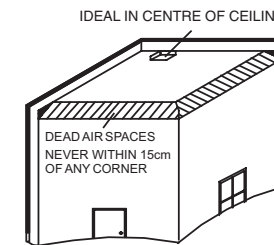

Figure 2

(b) Locations to Avoid

Don't place your Heat Alarm in any of the following areas:

Places where extremes of temperature may occur - below 4°C or above 43°C. e.g. attics, furnace rooms etc. Directly above ovens or kettles as the heat/steam could cause nuisance alarms.

Bathrooms, shower rooms or other rooms where the unit may be triggered by steam or condensation.

4

Near a **decorative object, door, light fitting, window molding** etc., that may prevent the heat reaching the unit. Surfaces that are normally **warmer** or **colder** than the rest of the room (for example attic hatches, uninsulated exterior walls etc).

Next to or directly above **heaters** or **air conditioning vents, windows, wall vents** etc. that can change the direction of airflow.

In very high or **awkward areas** (eg. over stair shafts) where it may be difficult to reach the alarm for testing and battery replacement.

Locate the unit at least 1 metre (3 feet) from **dimmer controlled lights and wiring** - some dimmers can cause interference.

Locate unit at least 1.5m (5 feet) and route wiring at least 1m (3 feet) away for **fluorescent light fittings** as electrical "noise" and/or flickering may affect the unit.

In excessively dirty or dusty locations where contamination build-up could slow down response.

Figure 3

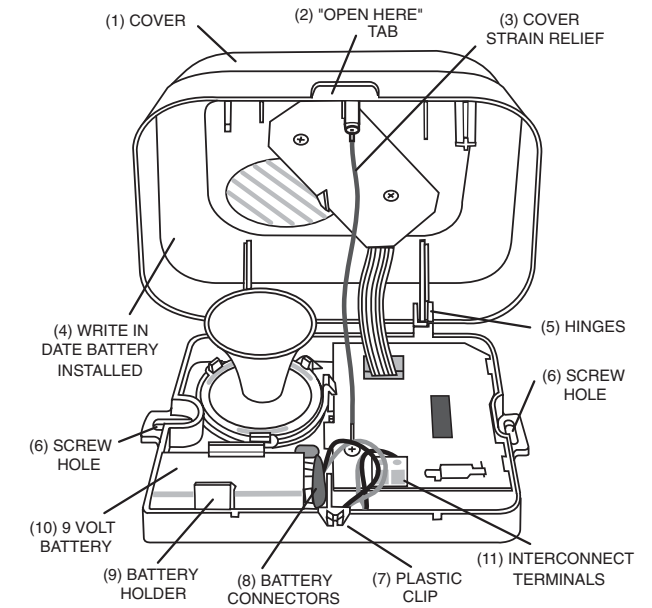

4. Installing your Heat Alarm

(a) Attaching to Ceiling .

(NB: for wiring the interconnect see page 7)

The Heat Alarm is battery operated. Use figure 3, as a help in mounting.

5

1. Pull Cover open at Tab (2). Do not remove Cover from base.
2. Place the Base on ceiling or wall exactly where you want to mount the unit. With a pencil, mark the location of the Screw Holes (6)
3. Taking care to avoid any electrical wiring in the ceiling, drill a hole through the centers of the marked locations. Push the plastic Screw Anchors provided into the drilled holes. Screw in firmly.

(b) Connecting the battery.

With a pencil, write the date of Battery installation on the inside of the Cover to remind you when to replace the battery (4).

Lift Battery from Battery holder, and snap Battery Connectors to Battery. They fit together only one way (Figure 4).

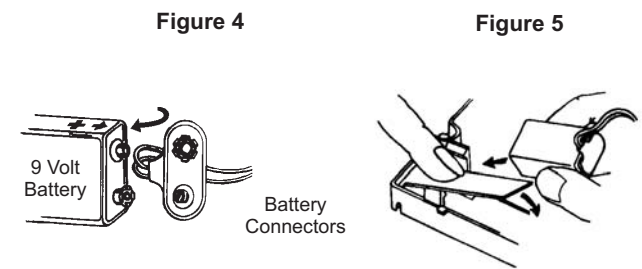

NOTE: You may hear a loud chirp when attaching the Battery Connectors to the Battery. Test the installed Heat Alarm - see section 6(a) below.

Some models will be fitted with a battery missing indicator warning flag which pops up when the battery is removed. This prevents the cover from closing when there is no battery in the unit. When the battery is being installed or changed, this flag must be held down while gently pushing the Battery into the Battery Holder. (see figure 5).

5. Interconnecting your Heat Alarms and Smoke Alarms.

A maximum of 12 interconnect EI 103, EI 100C and EI 105C Heat/Smoke Alarms may be wired together so that when one unit senses fire all other units sound a warning. This helps ensure the alarms will be heard.

Warning: Do not interconnect to any other Heat / Smoke Alarms

A maximum of 820 feet (250 metres) of wire can be used, (maximum resistance between detectors 50 ohm). The units are inter-connected by wiring all the terminals marked 1 together, and all the terminals marked 2 together, as shown in Figure 6. An opening should be made in the label covering the wiring hole in the base, and the wires routed into the unit as shown. Note that the

wiring inside the unit must be kept clear of the test button contacts, and must not impede the air flow. Drafts from wiring openings, conduit, or mounting boxes/holes, may blow smoke away from the sensing chamber, making it insensitive. It is essential that all such openings be closed by silicone sealant or similar.

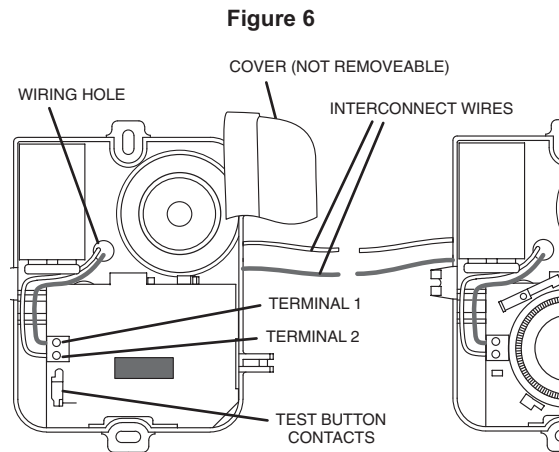

After wiring together the Interconnect Alarms, test the first unit by pressing the button. All the detectors should alarm within 10 seconds and the red light **only** on the unit being tested, will flash about once a second. Check all the other units similarly.

These Alarms should be interconnected only within the confines of a single family living unit. If they are connected between different units there may be excessive nuisance alarms. Everybody may not be aware that they are being tested or that it is a nuisance alarm caused by cooking etc.

6. Looking after your Heat Alarm

(a) Testing your Heat Alarm

It is recommended that you test your Heat Alarm once a week to be sure the unit is working. Press and hold the Test Button until the alarm sounds (it may take up to 10 seconds) see figure 7. It will also help you and your family to become familiar with the sound of the Alarm.

(b) Testing with Heat

When you press the Test Button it simulates the effect of Heat during a real fire. So, there is no need to test the Alarm with Heat.

WARNING: Do not test with flame.
This can be a fire hazard in itself.

If you want to check your Alarm with heat we recommend using a hair dryer with a power rating of at least 1000 watts. Direct the hot air as shown in figure 8 on to the heat sensor and the alarm should sound within 30 seconds.



Figure 7

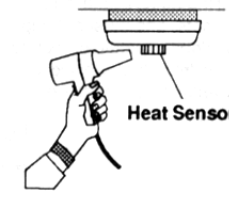

Figure 8

If the alarm fails to sound, follow this checklist.

1. Check Battery Connectors to be sure they are firmly snapped to the Battery.
2. Replace the Battery. (Check the date marked on the Cover when you last replaced the Battery).
3. Refer to "Cleaning Your Heat Alarm" 6 (d).

(c) Replacing the Battery.

A fresh battery should last about one year. When battery power is low and replacement is necessary, the Alarm will "beep" about once per minute for at least 30 days. The battery must then be replaced. Replace battery if the alarm does not sound when the Test Button is pressed. For maximum reliability, replace battery at least once a year.

If the Power Indicator light ceases flashing every 40 seconds replace the battery. Be sure to replace the battery as soon as possible to ensure proper operation and to avoid a leaking battery. Leakage could cause damage to the Alarm, furniture, and carpeting.

For replacement batteries, refer to the label inside the Heat Alarm Cover.

WARNING: Use of any other battery may be detrimental to the operation of the Heat Alarm.

(d) Cleaning your Heat Alarm

Heat Alarms are not as susceptible to dust and contamination as Smoke Alarms but it is prudent to clean them periodically. Use the narrow nozzle attachment of your vacuum cleaner to remove dust, insects and cobwebs from the sides and cover slots where the heat enters. To clean the cover, wipe with a damp cloth. Dry cover thoroughly with cloth.

WARNING: Do not paint your Heat Alarm.

Other than the cleaning described above, no other customer servicing of this product is required. Repairs, when needed, must be performed by the manufacturer.

7. Nuisance Alarms

If, when the alarm goes off, there is no sign of smoke, heat or noise to indicate that there is a fire, you should get your family into a safe place, before you start investigating.

Check the house carefully in case there is a small fire smouldering somewhere.

Check whether there is some source of heat, fumes or smoke, for example steam from a kettle triggering a Heat Alarm or cooking fumes being drawn past a Smoke Alarm by an extractor. The Heat Alarm or Smoke Alarm initiating the alarm can be identified as it will have a rapidly flashing red light. If there are frequent nuisance/false alarms it may be necessary to re-locate the offending device away from the cause of the alarm.

8. (a) Important Safeguards

When using household protective devices, basic safety precautions should always be followed, including those listed below:

Please read all instructions.

Rehearse emergency escape plans so everyone at home knows what to do in case the alarm sounds.

For replacement batteries, refer to label inside Heat Alarm.

NOTE: Constant exposure to high or freezing temperatures or high humidity may reduce the life of the batteries.

Do not disconnect battery to stop alarm sounding. (Fanning vigorously with a newspaper or similar will remove heat from the Heat Alarm and stop it sounding.)

Do not attempt to recharge or burn batteries, as they may explode. Wrap in paper and discard normally.

When removing battery, handle carefully to avoid possible eye damage or skin irritation if battery has leaked or corroded.

To maintain sensitivity to heat, do not paint or cover Heat Alarm in any manner; do not permit any accumulation of cobwebs, dust or grease.

If unit has been damaged in any way or does not function properly, do not attempt a repair. Return Heat Alarm (see - Getting your Heat Alarm Serviced page 11.)

This appliance is only intended for premises having a residential type environment.

This is not a portable product. It must be mounted following the instructions in this leaflet.

Heat Alarms are not a substitute for insurance. The supplier or manufacturer is not your insurer.

(b) Limitations of Heat Alarms

Heat Alarms combined with Smoke Alarms can significantly help to reduce the risk of fire fatalities.

However independent authorities have stated that these systems may be ineffective in some fire situations. There are a number of reasons for this:

Heat Alarms will not work if the batteries are depleted or if they are not connected, or if the wrong type of battery is used. Test regularly and replace batteries at least yearly or when depleted.

Alarms will not detect fire if sufficient heat/smoke does not reach the alarms. Heat/smoke may be prevented from reaching the Alarm if the fire is too far away, for example, if the fire is on another floor, behind a closed door, in a chimney, in a wall cavity, or if the prevailing air drafts carry the heat/smoke away. Installing heat alarms and smoke alarms on both sides of closed doors and throughout the house or premises as recommended in this leaflet will very significantly improve the probability of early detection.

The Alarms may not be heard.

An alarm may not wake a person who has taken drugs or alcohol.

The alarms may not detect every type of fire to give sufficient early warning. They are particularly ineffective with: fires caused by smoking in bed, escaping gas, violent explosions, poor storage of flammable rags and/or liquids, (for example petrol, paint, spirits etc), overloaded electrical circuits, arson, children playing with matches.

The Alarms don't last indefinitely. The manufacturer recommends regular weekly testing and replacement after, at most, 10 years, as a precaution.

9. (a) Planning your Escape for when the Alarm goes off

Use the Heat Alarm and Smoke Alarm test buttons to familiarize your family and other occupants with the Alarm sound and to practice fire drills regularly with all occupants. Draw up a floor plan that will show each member at least 2 escape routes from each room in the house. Children tend to hide when they don't know what to do. Teach children how to escape, open windows, and use roll up fire ladders and stools without adult help. Make sure they know what to do if the alarm goes off - see below.



1. Check room doors for heat or smoke. Do not open a hot door. Use an alternate escape route. Close doors behind you as you leave.



2. If smoke is heavy, crawl out, staying close to floor. Take short breaths, if possible, through a wet cloth or hold your breath. More people die from smoke inhalation than from flames.



3. Get out as fast as you can. Do not stop for packing. Have a pre-arranged meeting place outside for all family members. Check everybody is there.



4. Call the Fire Brigade from a neighbour's house. Remember to give your name and address.



5. **NEVER** re-enter a burning house.

(b) Fire Safety Hints

Store petrol and other flammable materials in proper containers.

Discard oily or flammable rags.

Always use a metal fireplace screen and have chimneys cleaned regularly.

Replace worn or damaged sockets, switches, home wiring and cracked or frayed electrical cords and plugs.

Do not overload electrical circuits.

Keep matches away from children.

Never smoke in bed. In rooms where you do smoke, always check under cushions for smouldering cigarettes and ashes.

Service central heating systems regularly.

Be sure all electrical appliances and tools have a recognised approval label.

Further information can be obtained from the Home office Publication entitled "Smoke Detectors in your Home" (FB2) or your local fire prevention officer.

10. Getting your Heat Alarm Serviced

If your Heat Alarm fails to work after you have read the sections on "Connecting the battery" and "Looking after your Heat Alarm" return it for repair or replacement in a padded box (battery disconnected) to "Customer Assistance and Information" at the nearest address given on the Heat Alarm or in this leaflet. State the nature of the fault, where the Heat Alarm was purchased and the date of purchase.

11. Five Year Product Guarantee

Ei Electronics guarantees this product (excluding battery) for five years from date of purchase against any defects that are due to faulty material or workmanship. This guarantee only applies to normal conditions of use and service, and does not include damage resulting from accident, neglect, misuse, unauthorised dismantling, or contamination howsoever caused. This guarantee excludes incidental and consequential damage. If this Heat Alarm should become defective within the warranty period, it must be returned to the E.I. Co, carefully packaged, with the problem clearly stated. (see "Getting Your Heat Alarm Serviced") We shall at our discretion repair or replace the faulty unit. Do not interfere with the Heat Alarm or attempt to tamper with it. This will invalidate the guarantee.

This guarantee is in addition to your statutory rights as a consumer.

Ei Electronics, 9 Grundy Street, Liverpool L5-9SG, U.K.

Ei Electronics, Shannon, Co.Clare, Ireland.



9 VOLT BATTERY HEAT ALARM

INSTRUCTION LEAFLET

Contains vital information on unit operation and installation. Read and retain carefully. If you are just installing the unit this leaflet **MUST** be given to the householder.



MODEL: EI 103C WITH INTERCONNECT